

--标准依据/According to the standard IEC 60383 & GB/T 1001.1--

**外形尺寸 Dimensions**

公称结构高度/Nominal spacing (P)	146mm± 4.7
公称直径/Nominal diameter (ΦD)	255mm±11.7
公称爬电距离/Nominal creepage distance	320mm±14.3
球窝连接/Ball and socket coupling- IEC 60120 & GB/T 4056	16A, R
净重/Net weight	≈3.6kg

**机械性能 Mechanical Performance**

最小机械破坏负荷/Min.Mechanical failing load	70kN
例行拉力试验负荷/Routine tension test load	35kN
打击强度/Mechanical impact strength- ANSI C29.1	45N·m

**电气性能 Electrical Performance**

雷电冲击干耐受电压/Dry Lighting impulse withstand voltage	100kV
工频干耐受电压/Power frequency withstand voltage, Dry	70kV
工频湿耐受电压/Power frequency withstand voltage, Wet	40kV
工频击穿电压/Power frequency puncture voltage	130kV
无线电干扰电压/Radio interference voltage	10kV/1MHz, ≤50μV
可见电晕电压/Visual corona voltage	铁帽/cap≥22kV, 钢脚/pin≥18kV

**其他/Others**

- 锌层厚度/Zinc thickness
  - └ 全部样品平均值/Average for all samples  
86μm (600g/m<sup>2</sup>)
  - └ 单个样品平均值/Average for one sample  
72μm (500g/m<sup>2</sup>)
- 铁帽上的标记/Mark on the cap
  - └ 商标/Trade mark (HL)
  - └ 生产年份/Year of the manufacture
  - └ 最小机械破坏负荷/Min.Mechanical failing load

**绝缘子串示意图  
Insulator string diagram:**

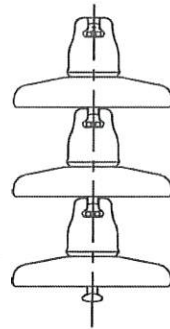

**绝缘子示意图  
Insulator diagram:**

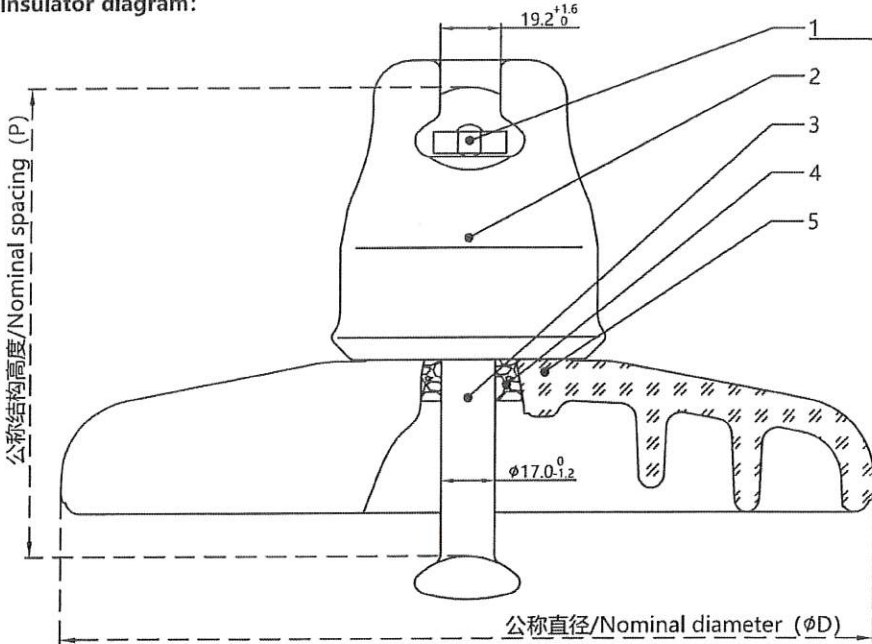

**组件/Component:**

- 1. 锁紧销/Split-Pin:
  - └ 不锈钢/Stainless Steel
- 2. 铁帽/Cap:
  - └ 铸铁, 热镀锌/Cast Iron, HDG
- 3. 钢脚/Pin:
  - └ 锻钢, 热镀锌/Forged Steel, HDG
- 4. 胶合剂/Cement:
  - └ 铝酸盐水泥/Aluminate Cement
- 5. 绝缘材料/Insulation material:
  - └ 钢化玻璃件/Tempered Glass

U70BL 盘形悬式玻璃绝缘子 Suspension Glass insulator		设计 Design	纪之云	山东瑞泰玻璃绝缘子有限公司 Shandong Ruitai Glass Insulator Co.,Ltd		
		审核 Check	王明			
比例 Scale	未按比例绘制 Not drawn to scale	批准 Confirm	石军	日期 Date	2024. 1. 10	70-146-320-16AR